

Service Schematics

NOKIA 5200/5300

RM-174, RM-181 / RM-146, RM-147

Introduction

Important:

This document is intended for use by authorized service centers only.

“Service Schematics” was created with focus on customer care. The purpose of this document is to provide further technical repair information for NOKIA mobile phones on Level 3/4 service activities. It contains additional information such as e.g. “Component finder”, “Frequency band table” or “Antenna switch table”. The “Signal overview” page gives a good and fast overview about the most important signals and voltages on board. Saving process time and improving the repair quality is the aim of this document. It is to be used additionally to the service manual and other training or service information such as Service Bulletins.

All measurements were made using following equipment:

Nokia repair SW	:	Phoenix version 2006.20.9.148
Oscilloscope	:	Fluke PM 3380A/B
Spectrum Analyzer	:	Advanced R3162 with an analog probe
RF-Generator/GSM Tester	:	Rhode & Schwarz CMU 200
Multimeter	:	Fluke 73 Series II

While every endeavour has been made to ensure the accuracy of this document, some errors may exist. If the reader finds any errors, NOKIA shall be notified in writing.

Please send E-Mail to: training.sace@nokia.com

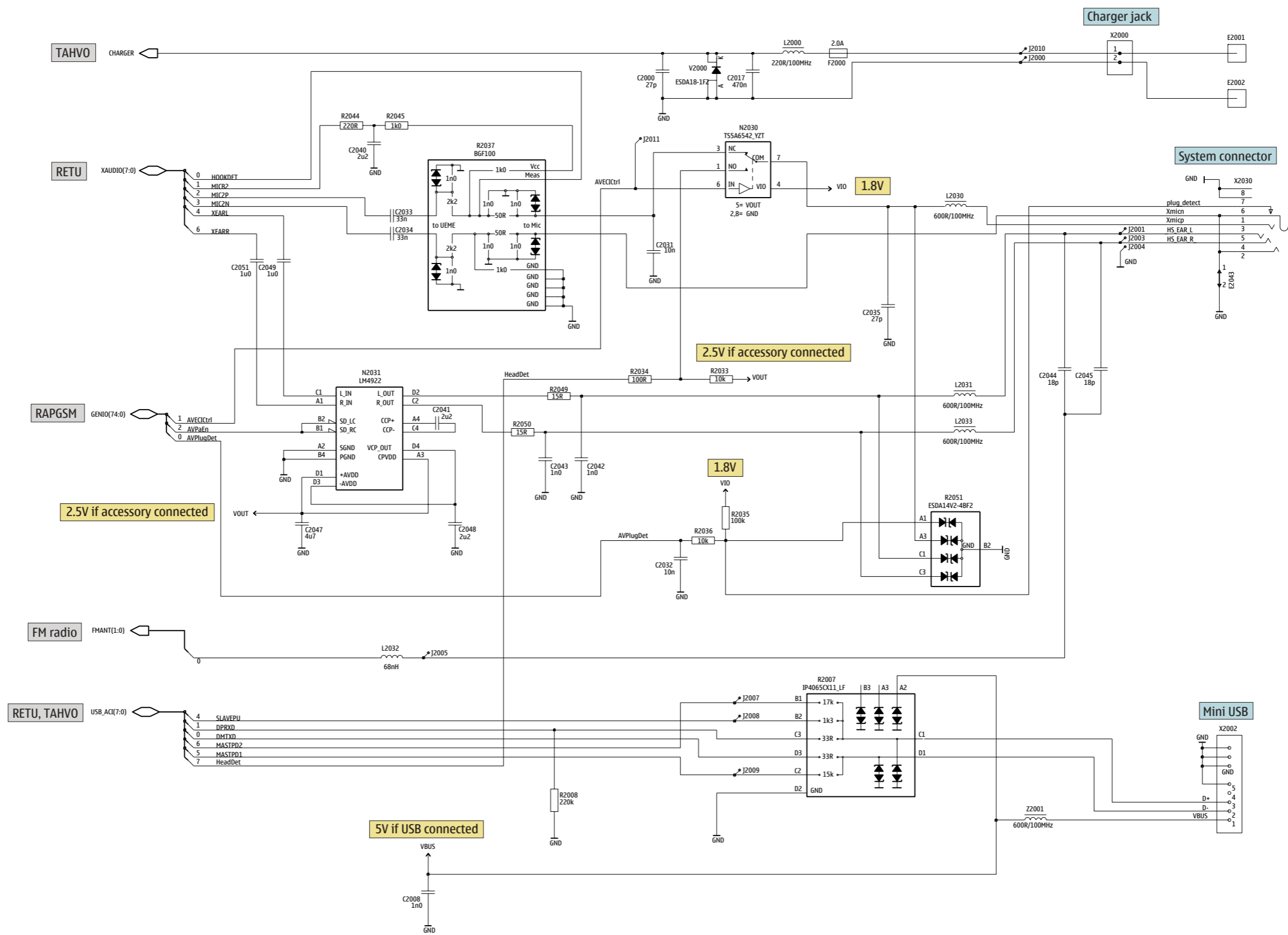

Table of content

Frontpage	1
System connector	2
RETU	3
TAHVO	4
RAPGSM, Combo memory	5
FM radio & Bluetooth	6
User interface	7
Camera, LCD interface, Earpiece, Mic 5200	8
Camera, LCD interface, Earpiece, Mic 5300	9
RF part	10
Signal overview	11
Component finder 5200	12
Component finder 5300	13

Copyright © NOKIA

This material, including documentation and any related computer programs is protected by copyright, controlled by NOKIA. All rights are reserved. Copying, including reproducing, modifying, storing, adapting or translating any or all of this material requires the prior written consent of NOKIA. This material also contains confidential information, which may not be disclosed to others without the prior written consent of NOKIA.



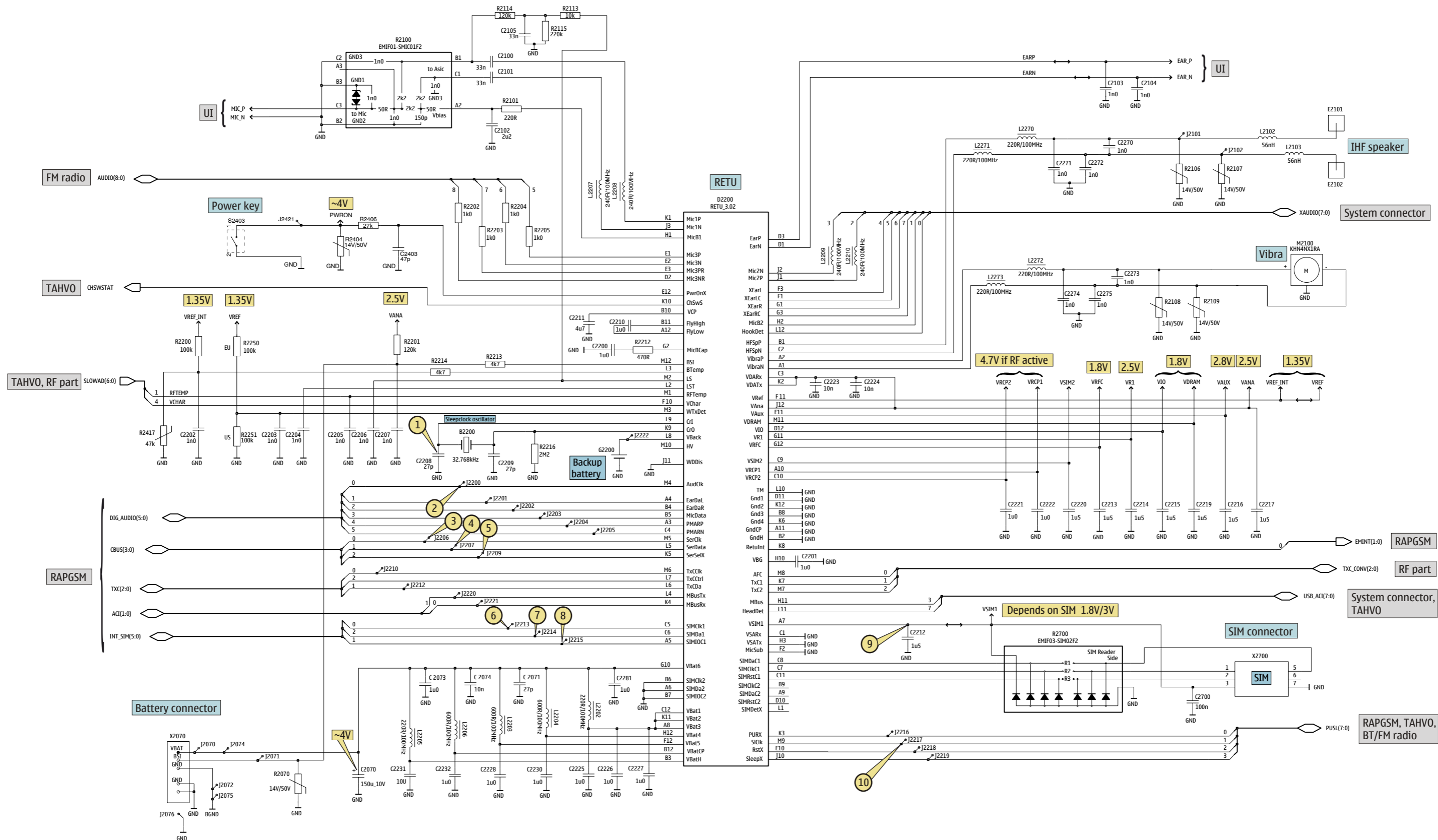

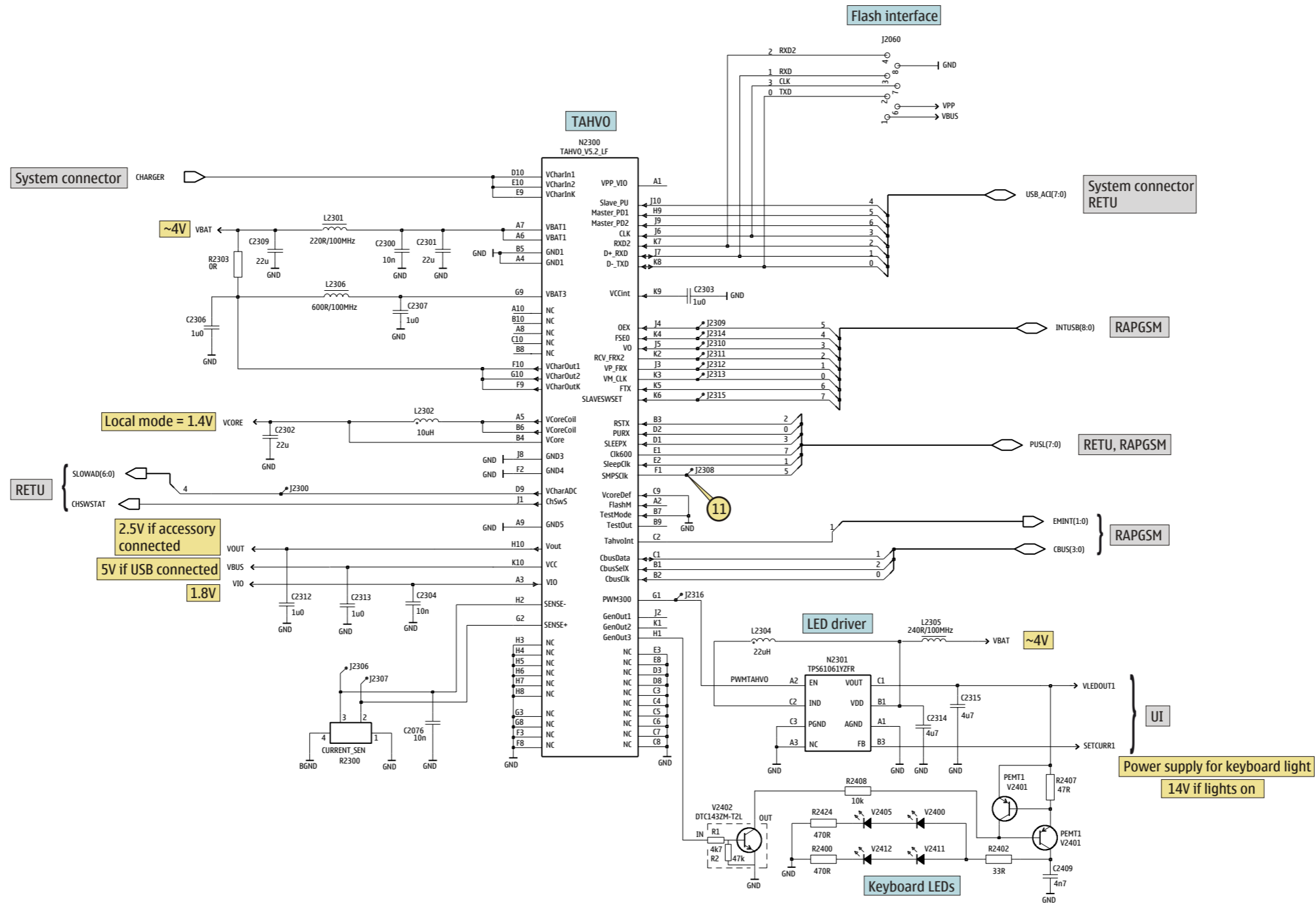

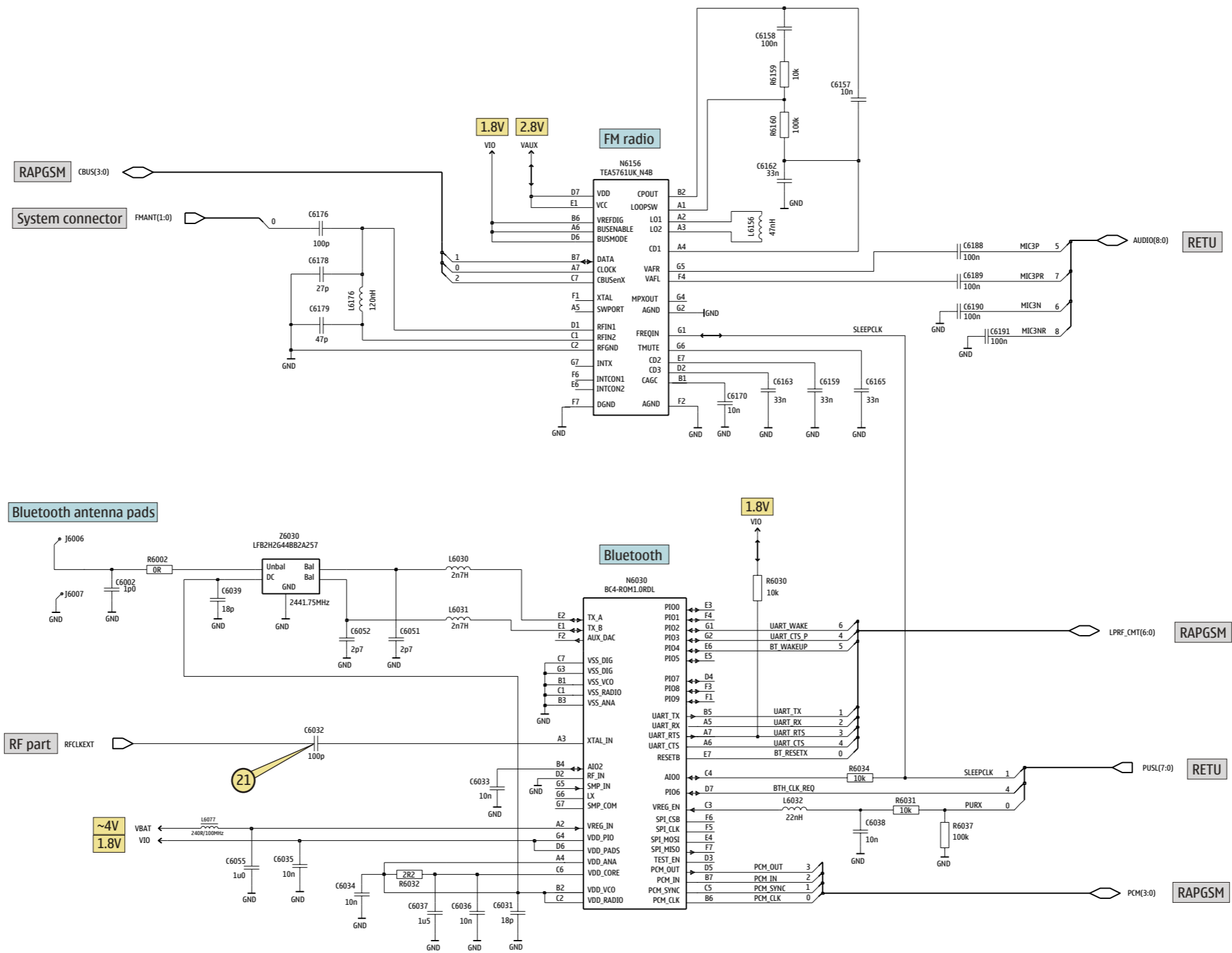

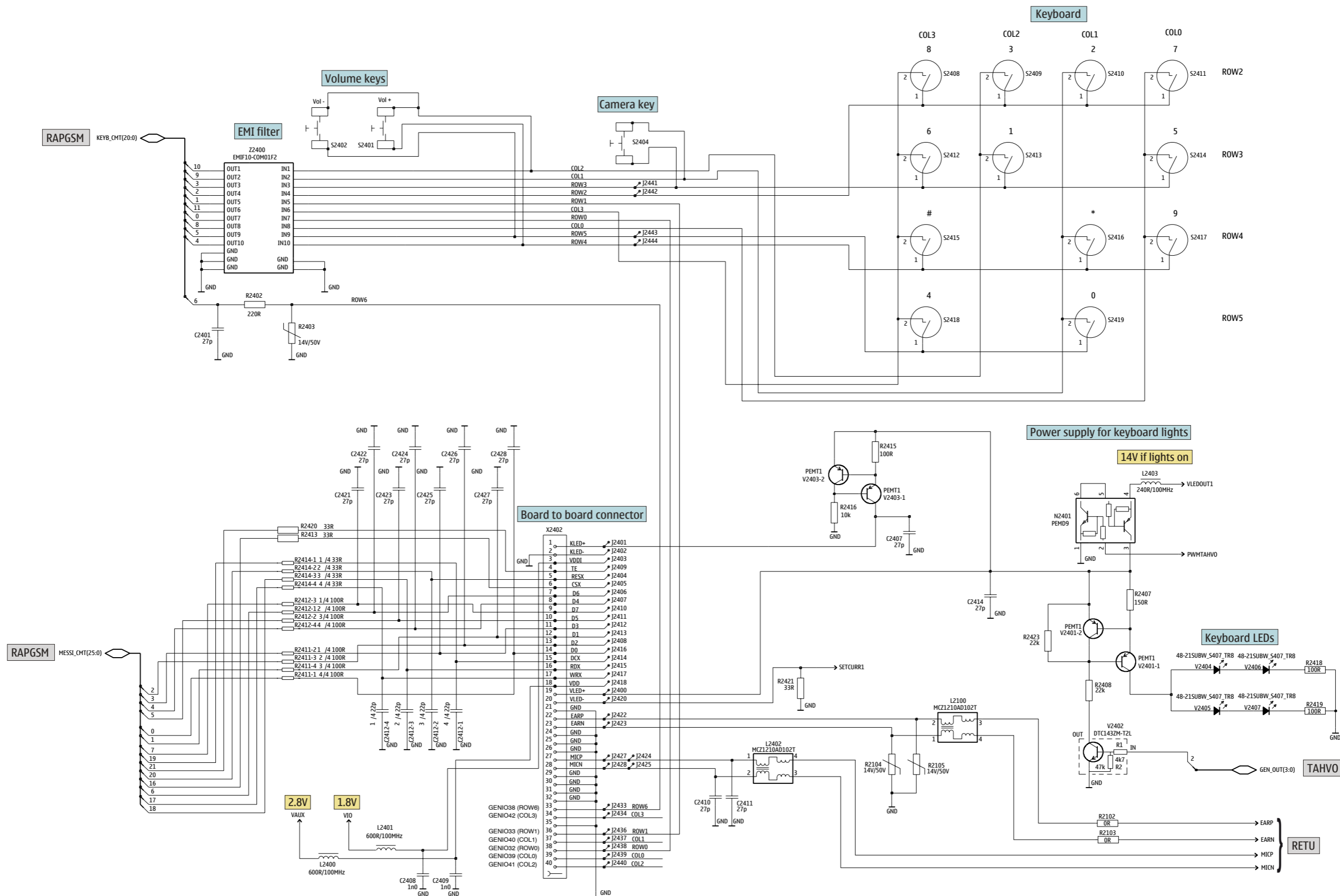

**Applies only for
Nokia 5200
(RM-174)!**

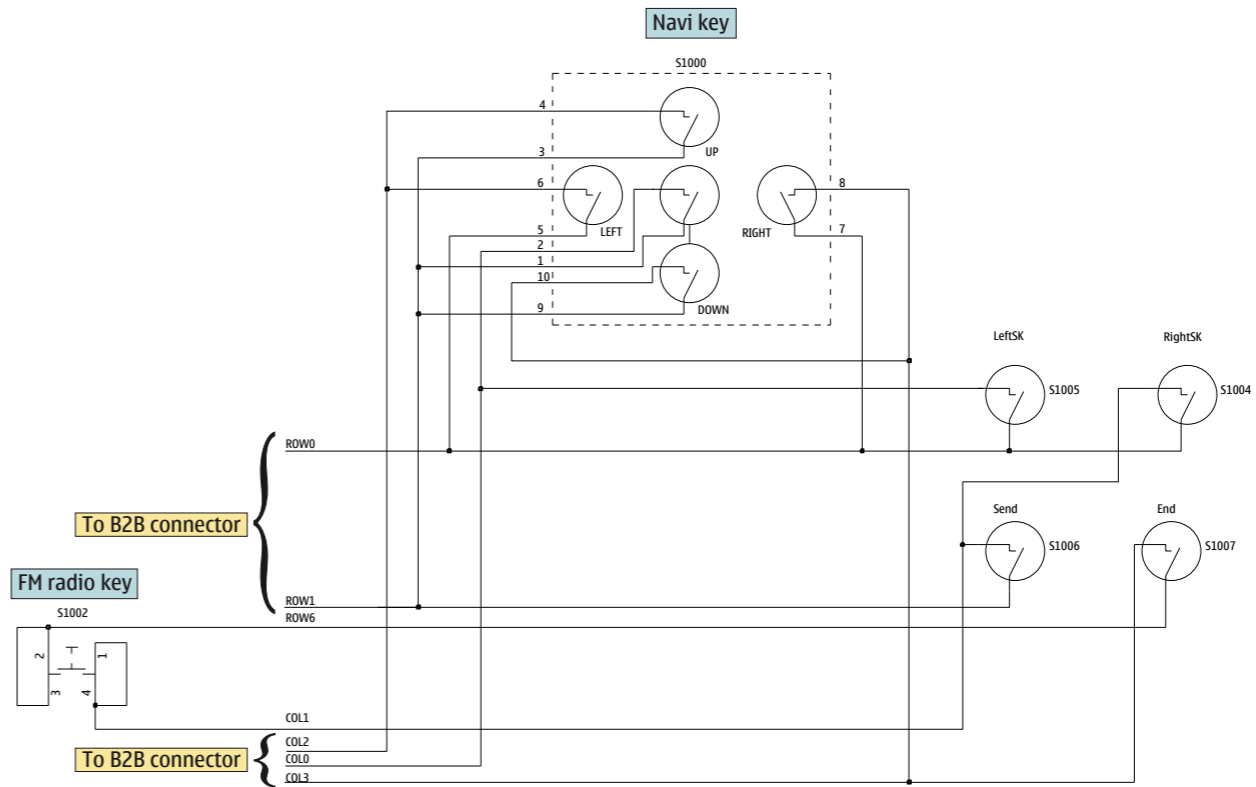
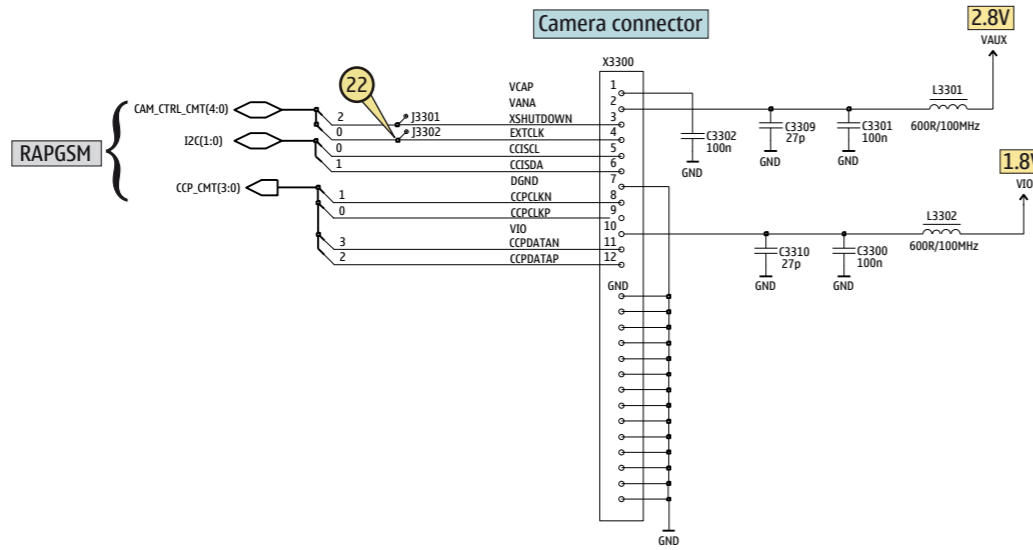
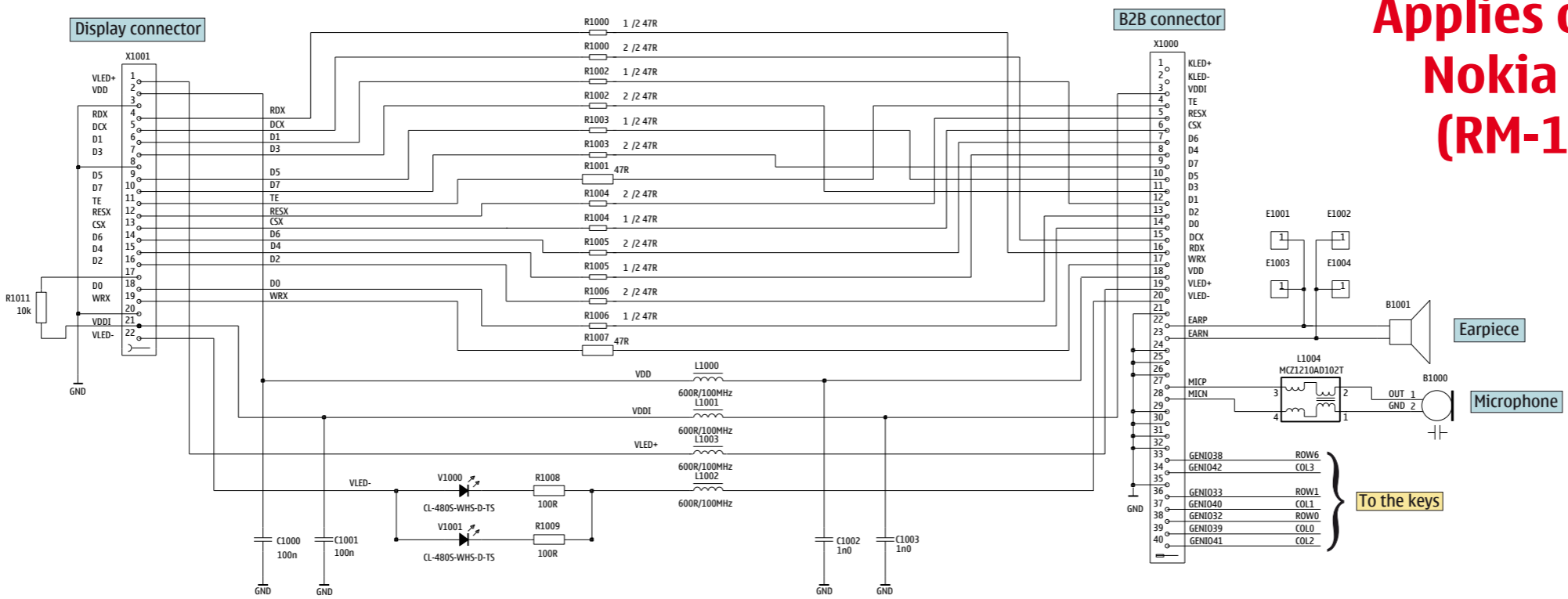

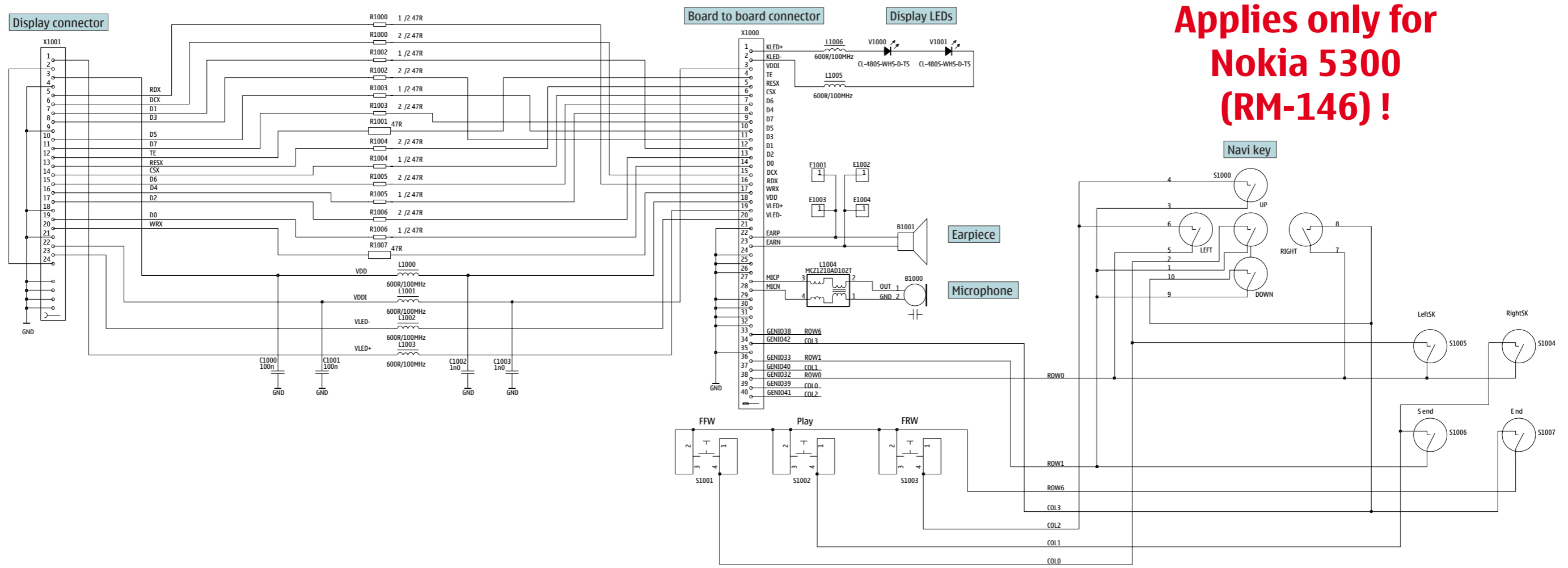

Applies only for Nokia 5300 (RM-146) !

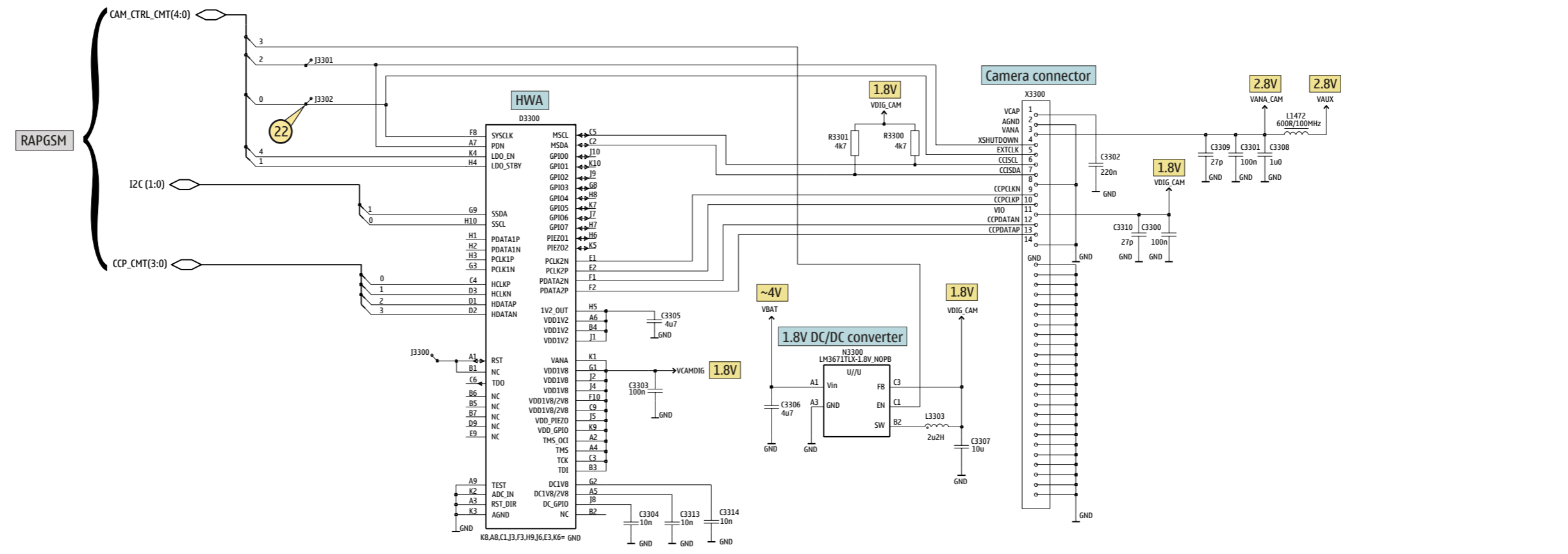

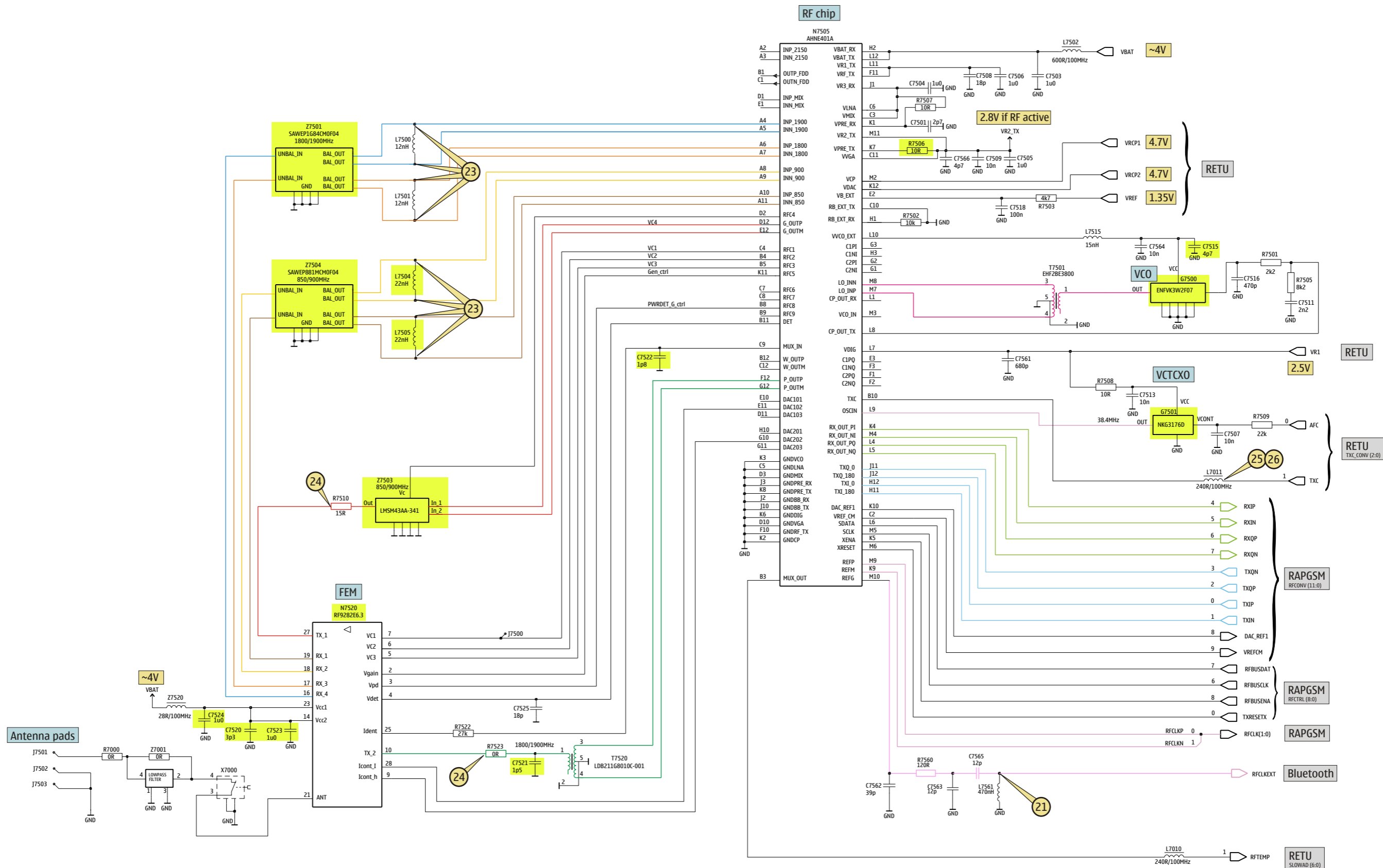

	C7515	C7520	C7521	C7523	C7524	G7500 (VCO)	G7501 (VCTX0)	L7504	L7505	N7520	R7506	Z7501	Z7503	Z7504
BOM1	4p7	3p3	1p5	na	na	Matsushita	NDK	22nH	22nH	RFMD 9282 E6.3	10R	Murata	Murata	Murata
BOM2	4p7	3p3	1p5	na	na	Matsushita	NDK	27nH	33nH	RFMD 9282 E6.3	10R	FMD	Epcos	Epcos

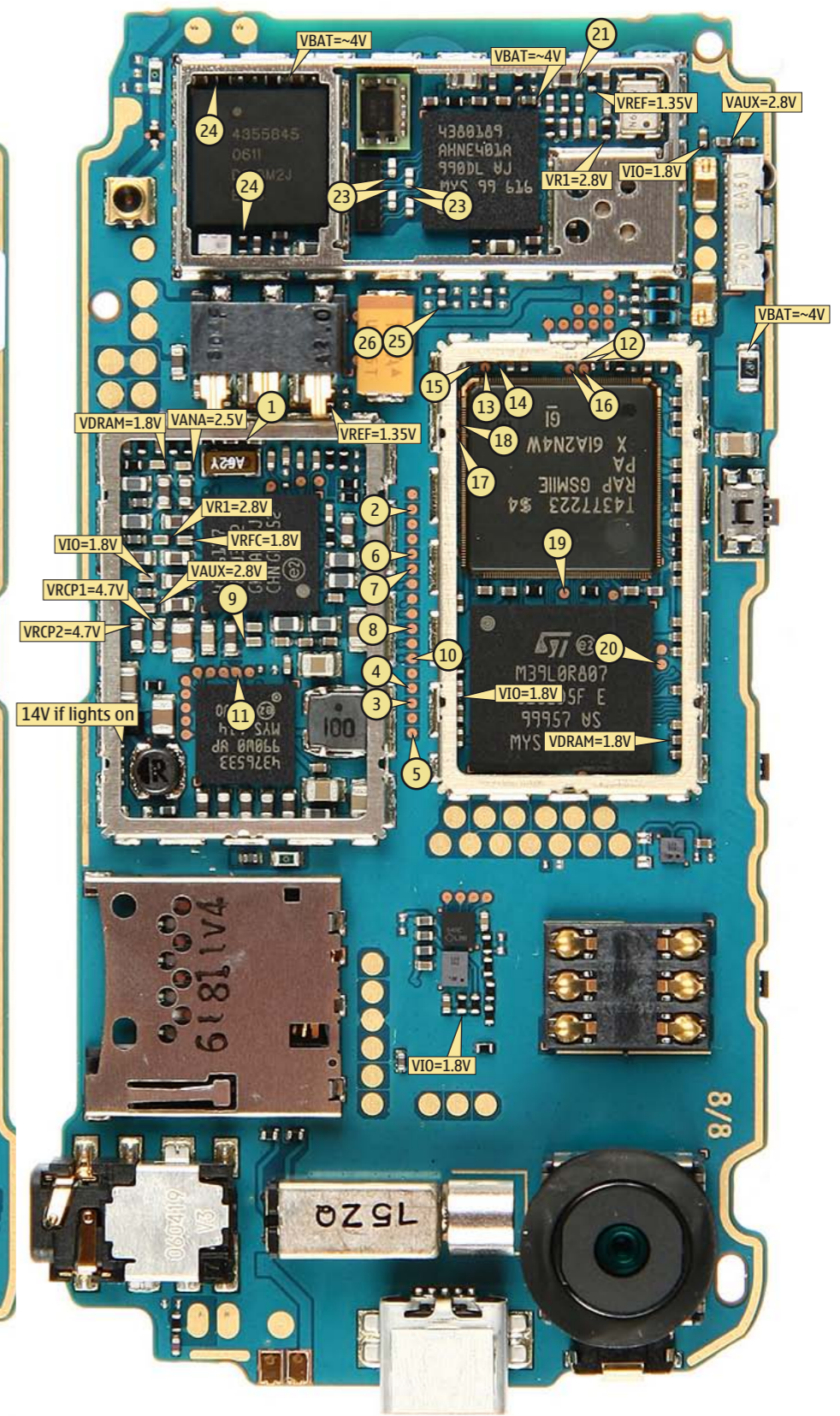
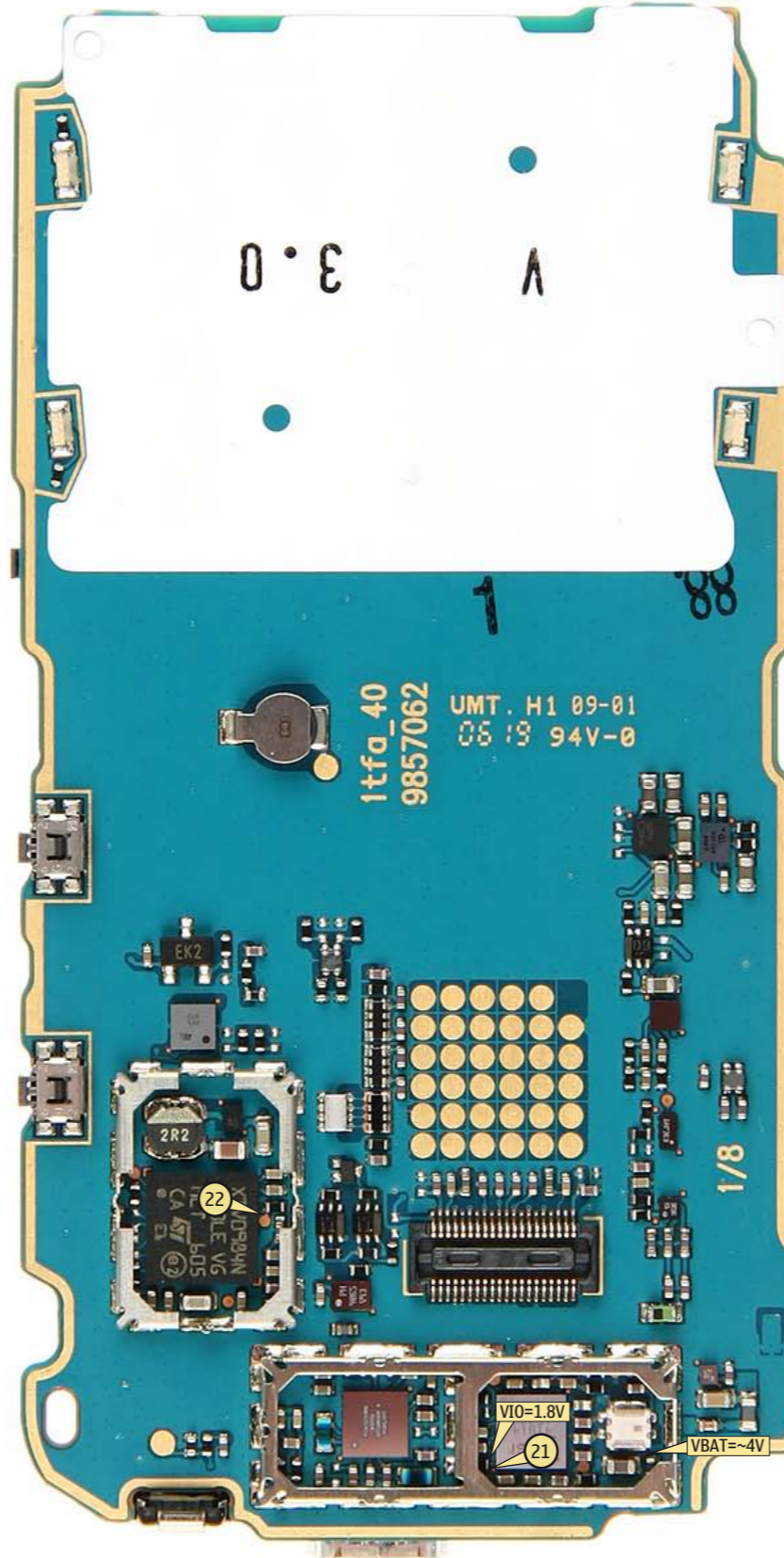
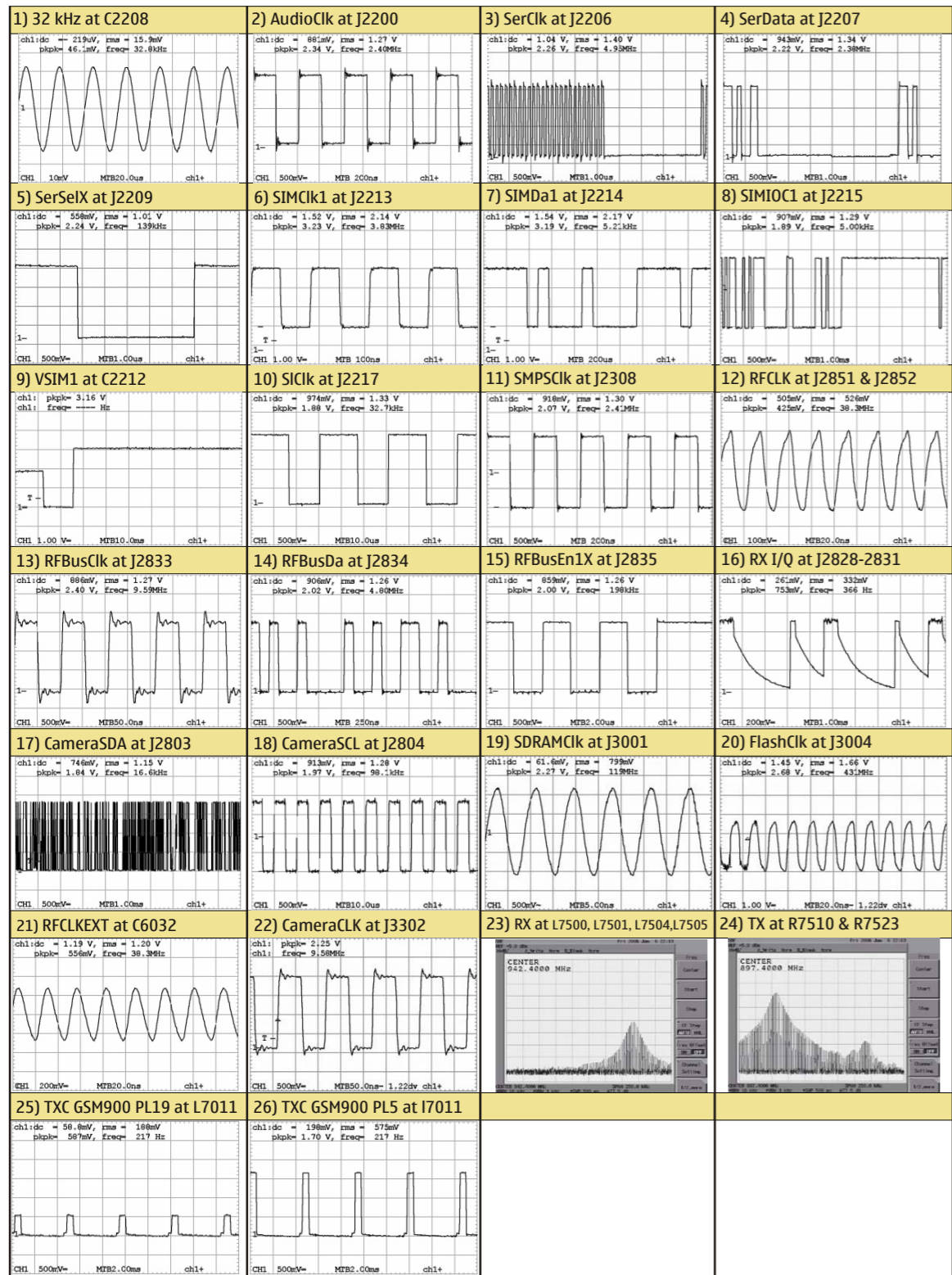

B	C2302	J5	C3201	G6	C7563	Q7	N2031	I3	R2830	N8	
B2200	M4	C2303	I3	C3202	G7	C7564	O8	N2300	I4	R2840	F7
C	C2304	J4	C3203	G6	C7565	Q7	N2301	J2	R3000	J6	
C2000	C2	C2305	H2	C3210	G3	C7566	Q8	N2400	H8	R3002	L9
C2008	D7	C2306	I4	C3242	F6	D	N2401	H3	R3003	K7	
C2017	C3	C2307	I4	C3300	C9	D2200	L4	N2600	P10	R3004	K8
C2030	F3	C2309	I5	C3301	C8	D2800	M8	N3200	G6	R3200	G6
C2031	I2	C2312	I4	C3302	C8	D3000	J8	N6030	C5	R3201	G7
C2032	E3	C2313	I3	C3309	C8	E	N6156	C6	R3202	G7	
C2033	I2	C2314	J3	C3310	C9	E2001	B4	N7505	P7	R3203	F7
C2034	I3	C2315	J2	C3321	C8	E2002	B4	N7520	P4	R3204	F7
C2035	F3	C2401	H7	C3322	G8	E2101	O9	R	R3242	F6	
C2040	I2	C2402	H8	C3323	G7	E2102	P9	R2007	D6	R3243	F6
C2041	I3	C2403	C8	C3324	C8	F	R2008	D6	R3312	G8	
C2042	H3	C2404	E6	C3325	D9	F2000	C3	R2033	F3	R3313	G7
C2043	H3	C2405	E6	C3326	C9	G	R2034	F3	R3314	D8	
C2044	D3	C2406	E4	C6001	B3	G2200	J7	R2035	E3	R6002	B3
C2045	D3	C2407	E4	C6002	B3	G7500	O8	R2036	E3	R6030	B5
C2046	I4	C2408	E4	C6031	C3	G7501	Q8	R2037	I3	R6031	C4
C2047	I3	C2409	E5	C6032	B5	L	R2044	I2	R6032	C5	
C2048	I3	C2410	F2	C6033	B5	L2000	C2	R2045	I2	R6034	B4
C2049	J3	C2411	F2	C6034	B4	L2030	E2	R2049	H3	R6037	C4
C2051	J3	C2412	F7	C6035	C5	L2031	E3	R2050	H3	R6156	C6
C2070	N5	C2413	I2	C6036	C5	L2032	D3	R2051	E3	R6159	B7
C2071	N3	C2414	E6	C6037	C5	L2033	E3	R2052	I4	R6160	B7
C2073	N3	C2415	H9	C6038	C4	L2100	H7	R2070	M3	R6161	C6
C2074	N3	C2416	F6	C6039	B4	L2102	N9	R2100	G3	R7000	Q3
C2100	G3	C2417	H6	C6040	C5	L2103	O9	R2101	H3	R7501	P8
C2101	G3	C2421	E4	C6051	B4	L2202	L2	R2102	H6	R7502	O6
C2102	H3	C2422	G6	C6052	C4	L2203	L2	R2103	H7	R7503	Q7
C2103	H7	C2423	E5	C6055	B4	L2204	L2	R2104	G7	R7505	P8
C2104	H7	C2424	G6	C6157	C7	L2205	L2	R2105	G7	R7506	Q7
C2105	G3	C2425	E5	C6158	C7	L2206	K2	R2106	N8	R7507	O7
C2111	O8	C2426	E5	C6159	C6	L2207	M5	R2107	O8	R7508	Q8
C2200	L5	C2427	F6	C6162	C7	L2208	M5	R2108	E4	R7509	Q8
C2201	L3	C2428	G6	C6163	B6	L2209	M5	R2109	E4	R7510	Q3
C2202	M2	C2600	M10	C6164	C6	L2210	M5	R2113	G3	R7522	Q4
C2203	M4	C2601	Q9	C6165	C6	L2270	K5	R2114	G3	R7523	O4
C2204	M4	C2602	Q10	C6167	B7	L2271	L5	R2115	G3	R7560	Q6
C2205	M5	C2603	Q9	C6170	B7	L2272	K4	R2200	M2	S	
C2206	M4	C2700	H9	C6176	B6	L2273	K5	R2201	M3	S2401	F10
C2207	M3	C2701	H9	C6178	B6	L2301	H5	R2202	L5	S2402	I10
C2208	M4	C2800	L9	C6179	B6	L2302	J5	R2203	L5	S2403	B8
C2209	M4	C2801	N9	C6188	C6	L2304	I3	R2204	L5	S2404	L10
C2210	K3	C2802	M9	C6189	C6	L2305	H3	R2205	L5	T	
C2211	K3	C2803	L9	C6190	C7	L2306	H4	R2212	L5	T7501	P8
C2212	K4	C2804	N9	C6191	C7	L2400	E5	R2213	M3	T7520	O3
C2213	L3	C2805	K6	C7000	Q2	L2401	E4	R2214	M2	V	
C2214	L3	C2807	N9	C7001	Q2	L2402	G2	R2216	M3	V2000	C3
C2215	K3	C2808	M9	C7010	O6	L2403	I2	R2250	M5	V2401	E6
C2216	K3	C2809	M9	C7011	O6	L2701	H9	R2251	M5	V2402	F6
C2217	M3	C2810	K9	C7012	O7	L3200	G6	R2303	H4	V2403	E7
C2218	L4	C2811	K7	C7013	O6	L3201	G6	R2401	H8	V2404	P2
C2219	M3	C2812	L9	C7501	O7	L3202	G7	R2402	H8	V2405	N2
C2220	K4	C2813	N6	C7502	Q7	L3301	D8	R2403	G7	V2406	P10
C2221	K2	C2814	M9	C7503	Q8	L3302	C9	R2404	C8	V2407	N10
C2222	K3	C2815	K9	C7504	O7	L6030	C4	R2406	C8	X	
C2223	K5	C2816	K9	C7505	Q8	L6031	C4	R2407	E6	X2000	B4
C2224	L5	C2818	K7	C7506	Q8	L6032	C4	R2408	E6	X2002	B6
C2225	L3	C2819	K8	C7507	Q8	L6077	B3	R2411	G6	X2030	D3
C2226	K3	C2820	N7	C7508	Q7	L6156	C7	R2412	G6	X2070	N4
C2227	K4	C2821	N7	C7509	Q8	L6176	B6	R2413	F6	X2402	E5
C2228	L3	C2830	N8	C7511	P8	L7010	O7	R2414	F6	X2700	F8
C2229	J4	C2831	N8	C7513	Q8	L7011	O6	R2415	E7	X3200	F3
C2230	L3	C3000	I6	C7515	O8	L7500	P6	R2416	E7	X3300	C8
C2231	K5	C3001	J6	C7516	P8	L7501	P5	R2417	E6	X7000	P2
C2232	K3	C3002	J6	C7518	Q7	L7502	Q7	R2418	Q10	Z	
C2270	K5	C3003	K9	C7520	O4	L7503	Q4	R2419	M10	Z2001	D7
C2271	K5	C3004	K9	C7521	O4	L7504	P6	R2420	G6	Z2400	G8
C2272	L5	C3005	J9	C7522	Q4	L7505	P5	R2421	J3	Z6030	C3
C2273	K4	C3006	J9	C7523	O4	L7515	P8	R2422	H3	Z7001	Q3
C2274	K4	C3007	J9	C7524	O5	L7561	Q6	R2423	E6	Z7501	P5
C2275	K5	C3008	J9	C7525	Q3	M	R2600	N10	Z7503	Q5	
C2281	L2	C3009	I9	C7560	P9	M2100	D5	R2700	H9	Z7504	P5
C2300	I5	C3100	H7	C7561	Q8	N	R2803	L9	Z7520	O5	
C2301	I5	C3200	G6	C7562	Q6	N2030	F3	R2804	L9		

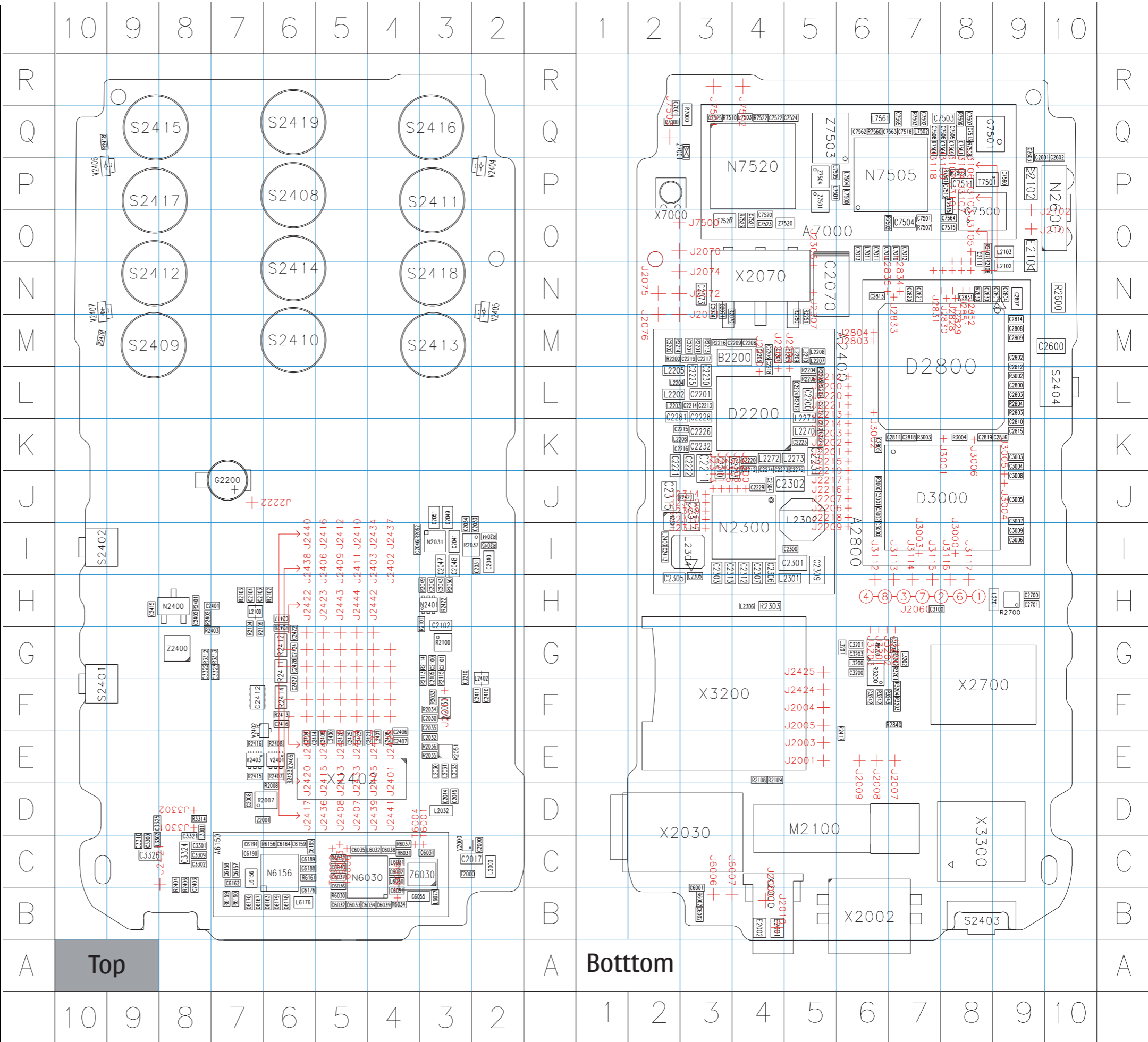

B	C2302	J5	C3201	G6	C7525	Q3	J2316	J3	J3300	E9	N2600	P10	R3003	K7	
B2200	M4	C2303	J3	C3202	G7	C7560	P9	J2400	F6	J3301	D8	N3200	G6	R3004	K8
C	C2304	J4	C3203	G6	C7561	Q8	J2401	F4	J3302	E7	N3300	F8	R3200	G6	
C2000	C2	C2305	H2	C3210	G3	C7562	Q6	J2402	G4	J6006	B3	N6030	C5	R3201	G7
C2008	D7	C2306	I4	C3242	F6	C7563	Q7	J2403	G4	J6007	B3	N6156	C6	R3202	G7
C2017	C3	C2307	I4	C3300	D9	C7564	Q8	J2404	F5	J7500	O2	N7505	P7	R3203	F7
C2030	F3	C2309	I5	C3301	D7	C7565	Q7	J2405	F4	J7502	R4	N7520	P4	R3204	F7
C2031	I2	C2312	I4	C3302	D7	C7566	Q8	J2406	G5	J7503	Q2	R	R3242	F6	
C2032	E3	C2313	I3	C3303	E7	D	J2407	F5	T6000	C5	R2007	D6	R3243	F6	
C2033	I2	C2314	J3	C3304	D8	D2200	L4	J2408	F5	T6001	C3	R2008	D6	R3300	D9
C2034	I3	C2315	J2	C3305	D8	D2800	M8	J2409	G5	T6002	C5	R2033	F3	R3301	E9
C2035	F3	C2401	H7	C3306	F7	D3000	J8	J2410	G5	T6003	C5	R2034	F3	R3306	E9
C2040	I2	C2402	H8	C3307	F8	D3300	E8	J2411	G5	T6004	C4	R2035	E3	R3307	E9
C2041	I3	C2403	C8	C3308	E7	E	J2412	G5	T6005	B4	R2036	E3	R3312	G8	
C2042	H3	C2404	E6	C3309	D7	E2001	B4	J2413	F5	L	R2037	I3	R3313	G7	
C2043	H3	C2405	E6	C3310	D9	E2002	B4	J2414	F5	L2000	C2	R2044	I2	R3314	E7
C2044	D3	C2406	E4	C3311	G8	E2101	O9	J2415	F5	L2030	E3	R2045	I2	R6002	B3
C2045	D3	C2407	E4	C3312	G7	E2102	P9	J2416	G5	L2031	E3	R2049	H3	R6030	B5
C2046	I4	C2408	E4	C3313	E7	F	J2417	F6	L2032	D3	R2050	H3	R6031	C4	
C2047	I3	C2409	E5	C3314	D8	F2000	C3	J2418	F5	L2033	E3	R2051	E3	R6032	C5
C2048	I3	C2410	F2	C6001	B3	G	J2420	F6	L2100	H7	R2052	I4	R6034	B4	
C2049	J3	C2411	F2	C6002	B3	G2200	J7	J2421	C8	L2102	N9	R2070	M3	R6037	C4
C2051	J3	C2412	F7	C6031	C3	G7500	O8	J2422	G6	L2103	O9	R2100	G3	R6156	C6
C2070	N5	C2413	I2	C6032	B5	G7501	Q8	J2423	G5	L2202	L2	R2101	H3	R6159	B7
C2071	N3	C2414	E6	C6033	B5	J	J2424	F5	L2203	L2	R2102	H6	R6160	B7	
C2073	N3	C2415	H9	C6034	B4	J2000	B4	J2425	G5	L2204	L2	R2103	H7	R6161	C6
C2074	N3	C2416	F6	C6035	C5	J2001	E5	J2427	F4	L2205	L2	R2104	G7	R7000	Q3
C2100	G3	C2417	H6	C6036	C5	J2003	E5	J2428	F4	L2206	K2	R2105	G7	R7501	P8
C2101	G3	C2421	E4	C6037	C5	J2004	F5	J2433	F5	L2207	M5	R2106	N8	R7502	O6
C2102	H3	C2422	G6	C6038	C4	J2005	F5	J2434	G4	L2208	M5	R2107	O8	R7503	Q7
C2103	H7	C2423	E5	C6039	B4	J2007	E7	J2436	D5	L2209	M5	R2108	E4	R7505	P8
C2104	H7	C2424	G6	C6040	C5	J2008	E6	J2437	G4	L2210	M5	R2109	E4	R7506	Q7
C2105	G3	C2425	E5	C6051	B4	J2009	E6	J2438	G6	L2270	K5	R2113	G3	R7507	O7
C2111	O8	C2426	E5	C6052	C4	J2010	B4	J2439	F4	L2271	L5	R2114	G3	R7508	Q8
C2200	L5	C2427	F6	C6055	B4	J2011	F3	J2440	G6	L2272	K4	R2115	G3	R7509	Q8
C2201	L3	C2428	G6	C6157	C7	J2060	H7	J2441	F4	L2273	K5	R2200	M2	R7510	Q3
C2202	M2	C2600	M10	C6158	C7	J2070	O2	J2442	G4	L2301	H5	R2201	M3	R7522	Q4
C2203	M9	C2601	Q9	C6159	C6	J2071	N2	J2443	G5	L2302	J5	R2202	L5	R7523	O4
C2204	M4	C2602	Q10	C6162	C7	J2072	N2	J2444	G5	L2304	I3	R2203	L5	R7560	Q6
C2205	M5	C2603	Q9	C6163	B6	J2074	N2	J2803	M6	L2305	H3	R2204	L5	S	
C2206	M4	C2700	H9	C6164	C6	J2075	N2	J2804	M6	L2306	H4	R2205	L5	S2401	F10
C2207	M3	C2701	H9	C6165	C6	J2076	N2	J2828	N8	L2400	E5	R2212	L5	S2402	I10
C2208	M4	C2800	L9	C6167	B7	J2101	O9	J2829	N8	L2401	E4	R2213	M3	S2403	B8
C2209	M4	C2801	N9	C6170	B7	J2102	O9	J2830	N8	L2402	G2	R2214	M2	S2404	L10
C2210	K3	C2802	M9	C6176	B6	J2200	L6	J2831	N8	L2403	I2	R2216	M3	T	
C2211	K3	C2803	L9	C6178	B6	J2201	K6	J2833	N7	L2701	H9	R2250	M5	T7501	P8
C2212	K4	C2804	N9	C6179	B6	J2202	K6	J2834	N7	L3200	G6	R2251	M5	T7520	O3
C2213	L3	C2805	K6	C6188	C6	J2203	K6	J2835	N6	L3201	G6	R2303	H4	V	
C2214	L3	C2807	N9	C6189	C6	J2204	L5	J2851	N8	L3202	G7	R2401	H8	V2000	C3
C2215	K3	C2808	M9	C6190	C7	J2205	L4	J2852	N8	L3301	E7	R2402	H8	V2401	E6
C2216	K3	C2809	M9	C6191	C7	J2206	J6	J3000	I8	L3303	F8	R2403	G7	V2402	F6
C2217	M3	C2810	K9	C7000	Q2	J2207	J6	J3001	K8	L6030	C4	R2404	C8	V2403	E7
C2218	L4	C2811	K7	C7001	Q2	J2209	I6	J3002	L6	L6031	C4	R2406	C8	V2404	P2
C2219	M3	C2812	L9	C7010	O6	J2210	L4	J3003	I7	L6032	C4	R2407	E6	V2405	N2
C2220	K4	C2813	N6	C7011	O6	J2212	L6	J3004	J9	L6077	B3	R2408	E6	V2406	P10
C2221	K2	C2814	M9	C7012	O7	J2213	L6	J3005	J9	L6156	C7	R2411	G6	V2407	N10
C2222	K3	C2815	K9	C7013	O6	J2214	K6	J3006	K8	L6176	B6	R2412	G6	V	
C2223	K5	C2816	K9	C7501	O7	J2215	K6	J3100	N8	L7010	O7	R2413	F6	X2000	B4
C2224	L5	C2818	K7	C7502	O7	J2216	J6	J3101	O8	L7011	O6	R2414	F6	X2002	B6
C2225	L3	C2819	N8	C7503	O8	J2217	J6	J3102	N8	L7500	P6	R2415	E7	X2030	D3
C2226	K3	C2820	N7	C7504	O7	J2218	J6	J3103	O8	L7501	P5	R2416	E7	X2070	N4
C2227	K4	C2821	N7	C7505	O8	J2219	J6	J3104	N8	L7502	Q7	R2417	E6	X2402	E5
C2228	L3	C2830	N8	C7506	O8	J2220	L6	J3105	O8	L7503	Q4	R2418	Q10	X2700	F8
C2229	J4	C2831	N8	C7507	O8	J2221	L6	J3106	N8	L7504	P6	R2419	M10	X3200	F3
C2230	L3	C3000	I6	C7508	Q7	J2222	J7	J3107	O8	L7505	P5	R2420	G6	X3300	C8
C2231	K5	C3001	J6	C7509	O8	J2300	J4	J3112	H6	L7515	P8	R2421	J3	X7000	P2
C2232	K3	C3002	J6	C7511	P8	J2306	N5	J3113	H7	L7561	Q6	R2422	H3	Z	
C2270	K5	C3003	K9	C7513	O8	J2307	N5	J3114	H7	M	R2423	E6	Z2001	D7	
C2271	K5	C3004	K9	C7515	O8	J2308	J4	J3115	H7	M2100	D5	R2600	N10	Z2400	G8
C2272	L5	C3005	J9	C7516	P8	J2309	J3	J3116	H8	N	R2700	H9	Z6030	C3	
C2273	K4	C3006	I9	C7518	Q7	J2310	J3	J3117	H8	N2030	F3	R2803	L9	Z7001	Q3
C2274	K4	C3007	J9	C7520	O4	J2311	J3	J3118	N7	N2031	I3	R2804	L9	Z7501	P5
C2275	K5	C3008	J9	C7521	O4	J2312	J3	J3200	G7	N2300	I4	R2830	N8	Z7503	Q5
C2281	L2	C3009	I9	C7522	O4	J2313	J3	J3201	G6	N2301	J2	R2840	F7	Z7504	P5
C2300	I5	C3100	H7	C7523	O4	J2314	J3	J3202	G6	N2400	H8	R3000	J6	Z7520	O5
C2301	I5	C3200	G6	C7524	O5	J2315	I3	J3203	G6	N2401	H3	R3002	L9		

